

**SILACOUNT 200**



**BALE WRAP COMPUTER**



The RDS **SILACOUNT 200** is a simple, user friendly instrument to monitor the amount of film applied to a bale and the total number of bales wrapped.

This instrument is a more comprehensive version of the **SILACOUNT 200**. It can display useful information such as wrapper RPM, work rate and numerous bale counts. The instrument can also operate an output to release the film or stop the wrapper.

**FEATURES**

Sealed to IP67

10-30V DC power supply

Programmable target bale revolutions

Internal & optional external audible alarm

Bale count register

**FEATURES**

Sealed to IP67

10-30V DC power supply

Programmable target bale revolutions

Internal & optional external audible alarm

8 resettable bale counts

Bale per hour

Optional film release or audio stop output

Programmable overspeed alarm



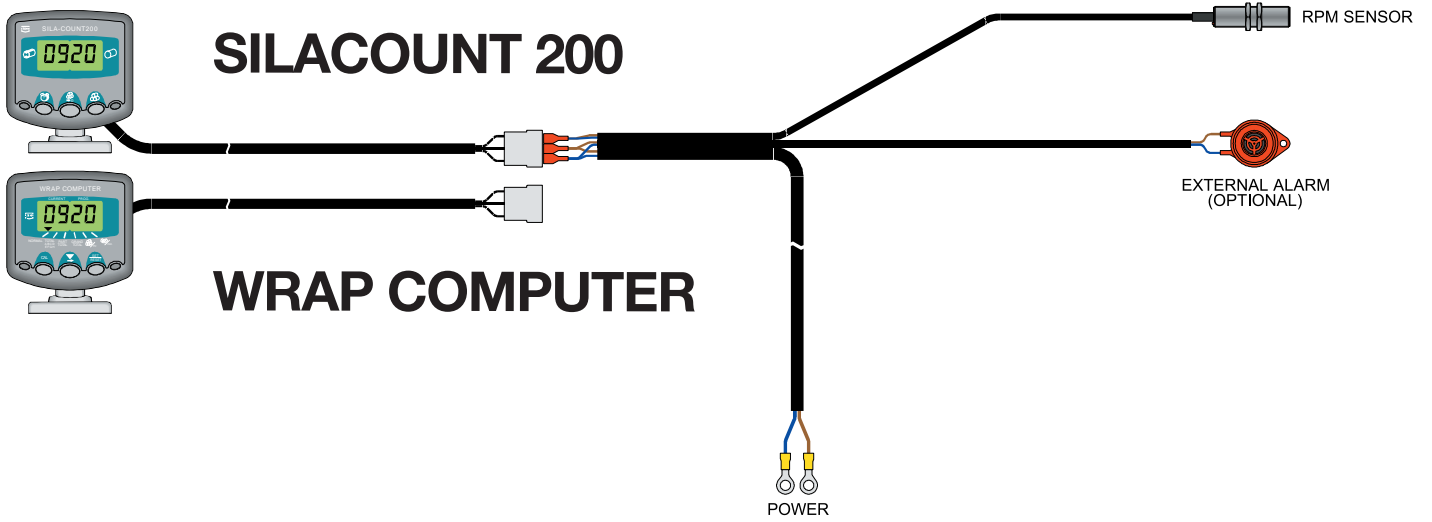

---

## DISTRIBUTORS

RDS Technology Ltd, Cirencester Road,  
Minchinhampton, Stroud, Glos GL6 9BH, UK  
T: +44 (0)1453 733300 info@rdstec.com

[www.rdstec.com](http://www.rdstec.com)

**RDS TECHNOLOGY**  
— TOPCON POSITIONING GROUP —